



QUICK START INSTRUCTIONS

SANTA FE
ULTRA98/120



800-533-7533
SANTA-FE-PRODUCTS.COM
TS-1199 05/21 REV. A

ASSEMBLY & INSTALLATION



Thanks for purchasing a Santa Fe ULTRA dehumidifier.
For a complete manual, visit www.santa-fe-products.com.
Please follow these steps to successfully assemble and install your new dehumidifier.

1 UNPACK BOX.

2 REGISTER WARRANTY AT SANTA-FE-PRODUCTS.COM



3 CHECK THAT YOU HAVE ALL PARTS:

- A. DEHUMIDIFIER (1)
- B. LEVELING FEET (4)
- C. FILTER - 14"X17.5"X1.75" MERV 13 (1)
- D. 10" ROUND DUCT COLLAR (2)
- E. 6" ROUND DUCT COLLAR (1)

A.



B.



C.



D.



E.



4 READ ALL REMAINING STEPS AND WARNINGS BEFORE CONTINUING.

5 CUT AND REMOVE SHIPPING ZIP TIE, INSERT COMPRESSOR PLUGS.

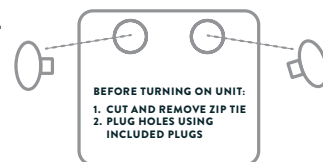

6 DECIDE WHERE TO PLACE UNIT.

⚠ WARNING! ALLOW FOR ENOUGH SPACING TO PROPERLY ROUTE YOUR RETURN AND SUPPLY CONNECTION

7 CHOOSE WHETHER TO PLACE ON FLOOR OR HANG DEHUMIDIFIER.

⚠ WARNING! INTERNAL STOPS LIMIT FEET HEIGHT. DO NOT TIGHTEN FEET BEYOND THE RESISTANCE PROVIDED BY STOPS.

A. IF YOU PLACE ON FLOOR, ATTACH LEVELING FEET.

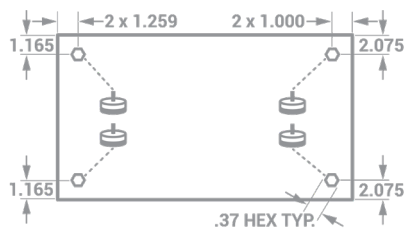

* RECOMMEND 6" TO 8" OFF GROUND
SEE MANUAL FOR MORE DETAILS

B. IF YOU HANG DEHUMIDIFIER, USE 2 BRACKETS* PER UNIT.

* BRACKETS SOLD SEPARATELY.



* NOTE: LEVELING FEET HOLD BRACKET IN PLACE

EXAMPLE OF HANGING OPTION:



8 OUTPUT TO DRAIN.

- A. ATTACH A P-TRAP (AVAILABLE AT MOST HARDWARE STORES).
- B. IF YOU NEED WATER TO TRAVEL A FURTHER DISTANCE, SEE SECTION 12 BELOW ON HOW TO ORDER A PUMP KIT.
- C. SEE MANUAL FOR MORE DETAILS. MANUAL CAN BE FOUND AT SANTA-FE-PRODUCTS.COM.



9 VERIFY WALL OUTLET IS CORRECT VOLTAGE AND AMPERAGE.

DOES REQUIRE A DEDICATED 120V 15 AMP CIRCUIT.

10 PLUG IN UNIT.

EXTERNAL CONTROLS ARE REQUIRED, SEE SECTION 12 BELOW ON HOW TO ORDER.

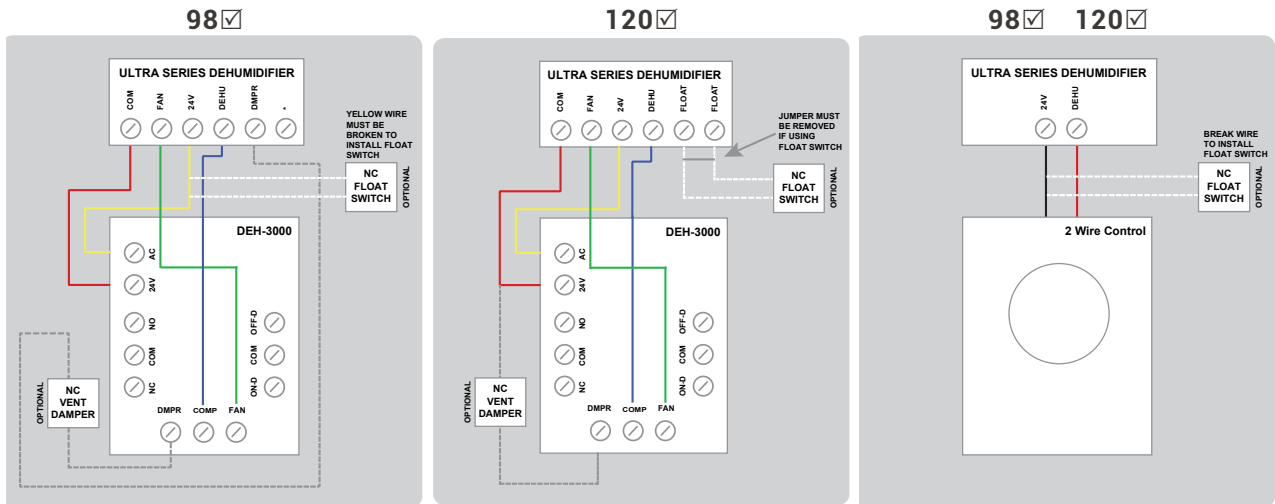

11 ACCESSORIES

FOR ADDITIONAL PRODUCT INFORMATION OR TO PURCHASE ADDITIONAL ACCESSORIES FOR YOUR SYSTEM, VISIT SANTA-FE-PRODUCTS.COM

- A. **REPLACEMENT FILTER:** Change the filter every 3 to 6 months or when the filter is visibly dirty.
 - PN 4037722 MERV-13 Filter
 - PN 4037731 MERV-13 Filter, 4-Pack
 - PN 4037732 MERV-13 Filter, 12-Pack
- B. **HANG KIT:** Recommended for hanging the dehumidifier overhead.
 - PN 4036695 Hang Kit
- C. **PUMP KIT:** Allows for draining and transferring water when the unit is not hard plumbed or near a drain.
 - PN 4022220 Condensate Pump



DO NOT RETURN TO RETAILER. FOR SERVICE OR TROUBLESHOOTING USE THE CONTACT INFORMATION BELOW.



NEED HELP? CALL US AT (800) 533.7533 OR VISIT US AT SANTA-FE-PRODUCTS.COM

ULTRA98/120 DEHUMIDIFIER

LIMITED WARRANTY

WARRANTOR

THERMA-STOR LLC
4201 LIEN RD., MADISON, WI 53704
1-800-533-7533

Limited Warranty. Therma-Stor, LLC ("Therma-Stor") warrants as follows: (i) the Santa Fe Ultra98/120 dehumidifier ("Product") will be free of material defects in workmanship or materials for a period of 2 years ("Two-Year Warranty") following the date of initial purchase of such Product by an original customer purchasing from Therma-Stor or an authorized reseller ("Customer"); and (ii) the Product's components will be free of material defects in workmanship or materials for a period of six (6) years following the date of initial purchase of such Product by a Customer.

Limitation of Remedies. CUSTOMER'S SOLE AND EXCLUSIVE REMEDY UNDER THE ABOVE LIMITED WARRANTY AND THERMA-STOR'S ENTIRE LIABILITY THEREUNDER, SHALL BE, AT THE SOLE OPTION OF THERMA-STOR, REPLACEMENT OR REPAIR OF SUCH PRODUCT OR ITS COMPONENTS ("COMPONENTS") BY THERMA-STOR OR THERMA-STOR'S AGENTS ONLY. REFRIGERANT, PIPING, SUPPLIES, TRANSPORTATION COSTS, LABOR COSTS INCURRED IN REPAIR OR REPLACEMENT OF SUCH COMPONENTS ARE NOT INCLUDED. THIS DISCLAIMER AND EXCLUSION SHALL APPLY EVEN IF THE EXPRESS WARRANTY AND LIMITED REMEDY SET FORTH HEREIN FAILS OF ITS ESSENTIAL PURPOSE. CUSTOMER ACKNOWLEDGES THAT NO REPRESENTATIVE OF THERMA-STOR OR OF ITS AFFILIATES OR RESELLERS IS AUTHORIZED TO MAKE ANY REPRESENTATION OR WARRANTY ON BEHALF OF THERMA-STOR OR ANY OF ITS AFFILIATES OR RESELLERS THAT IS NOT IN THIS AGREEMENT. Notwithstanding the above, during the term of the Two-Year Warranty only, Therma-Stor will provide, free of charge to Customer, all Components and labor (except costs related to removal and installation of Product) required to fulfill its obligations under such Two-Year Warranty.

Disclaimer of Warranties. EXCEPT FOR ABOVE LIMITED WARRANTY, WHICH IS THE SOLE AND EXCLUSIVE WARRANTY PROVIDED WITH RESPECT TO THE PRODUCT AND ITS COMPONENTS, THERMA-STOR HEREBY DISCLAIMS ALL EXPRESS AND IMPLIED WARRANTIES, INCLUDING, WITHOUT LIMITATION, THE IMPLIED WARRANTIES OF MERCHANTABILITY AND FITNESS FOR A PARTICULAR PURPOSE.

Warranty Limitations. The foregoing limited warranty extends only to a Customer and shall be null and void upon attempted assignment or transfer. A "defect" under the terms of the limited warranty shall not include problems resulting from Customer's or Customer's employees', agents', invitees' or a third party's misuse, improper installation, improper design of any system in which the Product is included, abuse, lack of normal care, failure to follow written instructions, tampering, improper repair, or freezing, corrosion, acts of nature or other causes not arising out of defects in Therma-Stor's workmanship or material. If a Product or Component is replaced while under warranty, the applicable limited warranty period shall not be extended beyond the original warranty time period. The limited warranty does not cover any costs related to changes to a Product or Component that may be required by any codes, laws, or regulations that may become effective after initial purchase of the Product by Customer.

Customer Responsibilities. As a further condition to obtaining warranty coverage hereunder, the Customer must send a valid warranty claim to Therma-Stor such that Therma-Stor receives such claim prior to the end of the applicable warranty period. Therma-Stor shall have no obligation hereunder with respect to any claim received by Therma-Stor after the expiration of the applicable warranty period. As a further condition to obtaining warranty coverage hereunder, the Customer must present forms of invoices evidencing proof of purchase of a Product. If such invoices do not clearly indicate the date of initial purchase by a Customer, the applicable Product's date of manufacture will be used instead of the date of initial purchase for the purpose of calculating the commencement of the applicable warranty period. Warranty service must be performed by Therma-Stor or a servicer authorized by Therma-Stor. In order to obtain warranty service, the Customer should call Therma-Stor at 1-800-533-7533 and ask for the Therma-Stor Products Service Department, which will then arrange for applicable warranty service. Warranty service will be performed during customary, daytime working hours. If the Product must be shipped for service, Customer shall be solely responsible for properly packaging the Product, for all freight charges, and for all risk of loss associated with shipment.

Limitation of Liability. IN NO EVENT SHALL THERMA-STOR, IN CONNECTION WITH THE DESIGN, SALE, INSTALLATION, USE, REPAIR, REPLACEMENT OR PERFORMANCE OF ANY PRODUCT, COMPONENT, PART THEREOF OR WRITTEN MATERIAL PROVIDED THEREWITH, BE LIABLE, TO THE EXTENT ALLOWED UNDER APPLICABLE LAW, UNDER ANY LEGAL THEORY FOR ANY SPECIAL, DIRECT, INDIRECT, COLLATERAL OR CONSEQUENTIAL DAMAGES OF ANY KIND. NOTWITHSTANDING THE ABOVE LIMITATIONS AND WARRANTIES, THE SOLE AND EXCLUSIVE LIABILITY OF THERMA-STOR, REGARDLESS OF THE NATURE OR THEORY OF THE CLAIM, SHALL UNDER NO CIRCUMSTANCES EXCEED THE PURCHASE PRICE OF THE PRODUCT, COMPONENT OR PART UPON WHICH THE CLAIM IS PREMISED.

Applicable Law and Venue. ANY ARBITRATION, ENFORCEMENT OF AN ARBITRATION OR LITIGATION RELATED TO THE PRODUCT WILL BE BROUGHT EXCLUSIVELY IN DANE COUNTY, WISCONSIN, AND CUSTOMER CONSENTS TO THE JURISDICTION OF THE FEDERAL AND STATE COURTS LOCATED THEREIN, SUBMITS TO THE JURISDICTION THEREOF AND WAIVES THE RIGHT TO CHANGE VENUE. CUSTOMER FURTHER CONSENTS TO THE EXERCISE OF PERSONAL JURISDICTION BY ANY SUCH COURT WITH RESPECT TO ANY SUCH PROCEEDING.

Miscellaneous. If any term or condition of this Limited Warranty is found by a court of competent jurisdiction to be invalid, illegal or otherwise unenforceable, the same shall not affect the other terms or conditions hereof or thereof or the whole of this Limited Warranty. Any delay or failure by Therma-Stor to exercise any right or remedy will not constitute a waiver of Therma-Stor to thereafter enforce such rights.

READ AND SAVE THESE INSTRUCTIONS

- The device is designed to be installed INDOORS IN A SPACE THAT IS PROTECTED FROM RAIN AND FLOODING.
- Install the unit with space to access the back or side panels for maintenance and service. DO NOT INSTALL UNIT WITH THE SERVICE PANELS INACCESSIBLE.
- Avoid directing the discharge air at people, or over the water in pool areas.
- If used near a pool, spa or water; be certain there is NO chance the unit could fall into the water, be splashed and that it is plugged into an outlet that is a GROUND FAULT INTERRUPT protected circuit.
- DO NOT use the device as a bench or table.
- DO NOT place the device directly on structural members. Provide vibration isolation in order to minimize operational vibration and/or noise.
- A drain pan MUST be placed under the unit if installed above a living area or above an area where water leakage could cause damage
- Never operate a unit with a damaged power cord. If the power cord is damaged it must be replaced by the manufacturer, its service agent, or similarly qualified person in order to avoid a hazard.
- Make all electrical connections in accordance with the current edition of the NEC ANSI/NFPA 70 and any national and local codes or ordinances that may apply
- Do not obstruct the air intake and exhaust. Maintain a .3 m (1 ft) clearance around the air intake and exhaust.
- This appliance is not intended for use by persons (including children) with reduced physical, sensory or mental capabilities, or lack of experience and knowledge, unless they have been given supervision or instruction concerning use of the appliance by a person responsible for their safety. Children should be supervised to ensure that they do not play with the appliance.